



Business Process related Knowledge Mapping

Bernard Donnay

b.donnay@mindnew.com

<http://www.mindnew.com>





New Mind S.A

• Focus on E-Learning



Medical



Banking

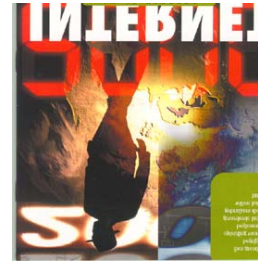

General Public



General Public



Institutional

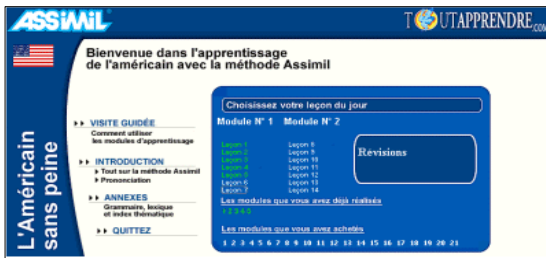

Language



Academic



Schools

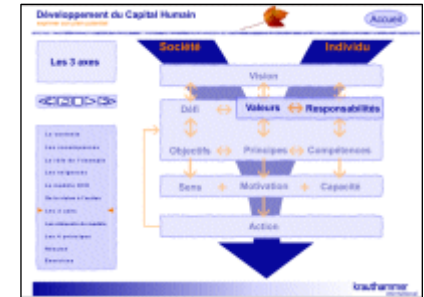

Corporate

• CD-ROMS and Internet

• Consulting





New Mind S.A: our customers

IBM

BBL(ING)

Artesia

Cortal

Air Products Europe

European Union

Ministerie van Defensie (Nederland)

United Nations (Brussels)

International Atomic Energy Agency (United Nations-Austria)

Eurolover Foundation

Fujisawa (Germany)

Europace (KUL)

Ministère des Affaires Economiques (Belgium)

Renault Belgium

Banksys

Région Wallonne (Belgium)

Carrefour, FNAC, CLUB, Colruyt, EXELL, PROXIS

Krauthammer International





Awards and Public Attention

Forum Multimédia

FESTIVAL Ciné Santé

SELECTION OFFICIELLE : CD-ROMS et DVD

*** Catégorie « Grand Public » :**

- Les envahisseurs invisibles – MONA LISA PRODUCTION - LYON (France) ;
- Longévité, mode d'emploi - Euro Santé Vidéo Production – PARIS (France) ;
- Premier contact : l'échographie de grossesse en famille – ESMAGE PRODUCTIONS – MONTAUBAN (France) ;
- Tout sur l'Allergie – MEVIPRO – HASSELT (Belgique) ;

*** Catégorie « Médical Scientifique » :**

- Cancers du larynx – Euro Santé Vidéo Production – PARIS (France) ;
- Du cerveau biologique... au cerveau psychiatrique – JANSSEN-CILAG – ISSY LES MOULINEAUX (France) ;
- Dysfonction érectile – Dr DEVAUX – PARIS (France) ;
- La douleur de l'enfant : la reconnaître, la traiter, l'évaluer – Association SPARADRAP – PARIS (France) ;
- Le Net cardiologique – SOLVAY PHARMA – SURESNES (France) ;
- Le traitement des fistules pancréatiques – UCB SA – BRUXELLES (Belgique) ;
- L'oncologie pratique à l'officine - Euro Santé Vidéo Production – PARIS (France) ;
- Organ transplantation : yesterday, today and tomorrow – Clinique Universitaire Saint Luc – BRUXELLES (Belgique) ;
- Panorama de l'HTA – SOLVAY PHARMA – SURESNES (France) ;
- TMS : comprendre et agir – I.N.R.S. – PARIS (France) ;
- Traitement percutané de l'incontinence d'urine par voie trans-obturatrice (réalisation en 3D) - Dr Monneins - Centre Hospitalier - Gonesses (France) ;
- Vectocardiographie et genèse de l'électrocardiogramme – SFRS / CERIMES – VANVES (France).



Press conference Finance Minister 2001

The site of the week-L'Echo



Internet in je vingers - 4 stars in CM



International Selection (Medical Media) 2003





Table of Content

- Anecdotes
- Definitions
- Mapping methods
- Business processes
- Knowledge Mapping





Anecdotes

- A merger case
- After sales support case
- Car rental case
- Market research case
- Expert System case

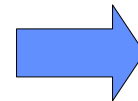

Food for thoughts





A merger: the scene (bank agencies)

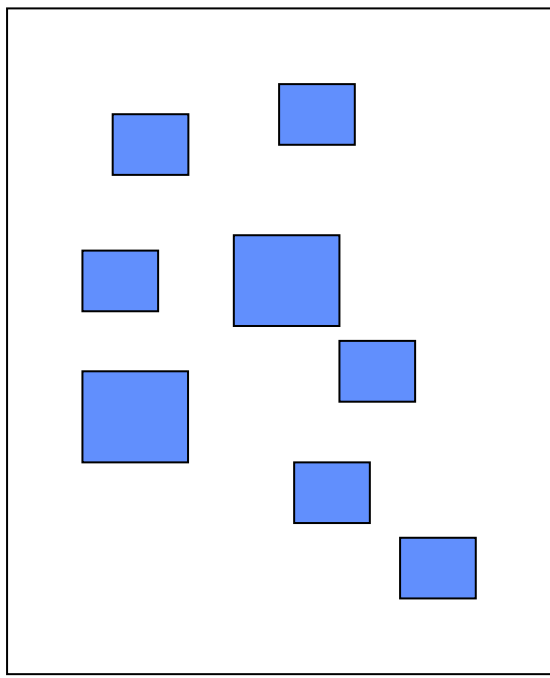

Agencies A

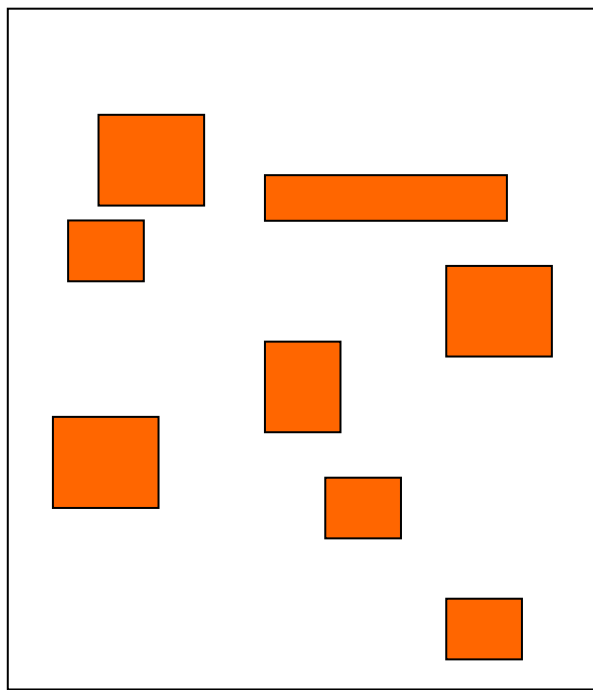

Agencies B





A merger: the know how

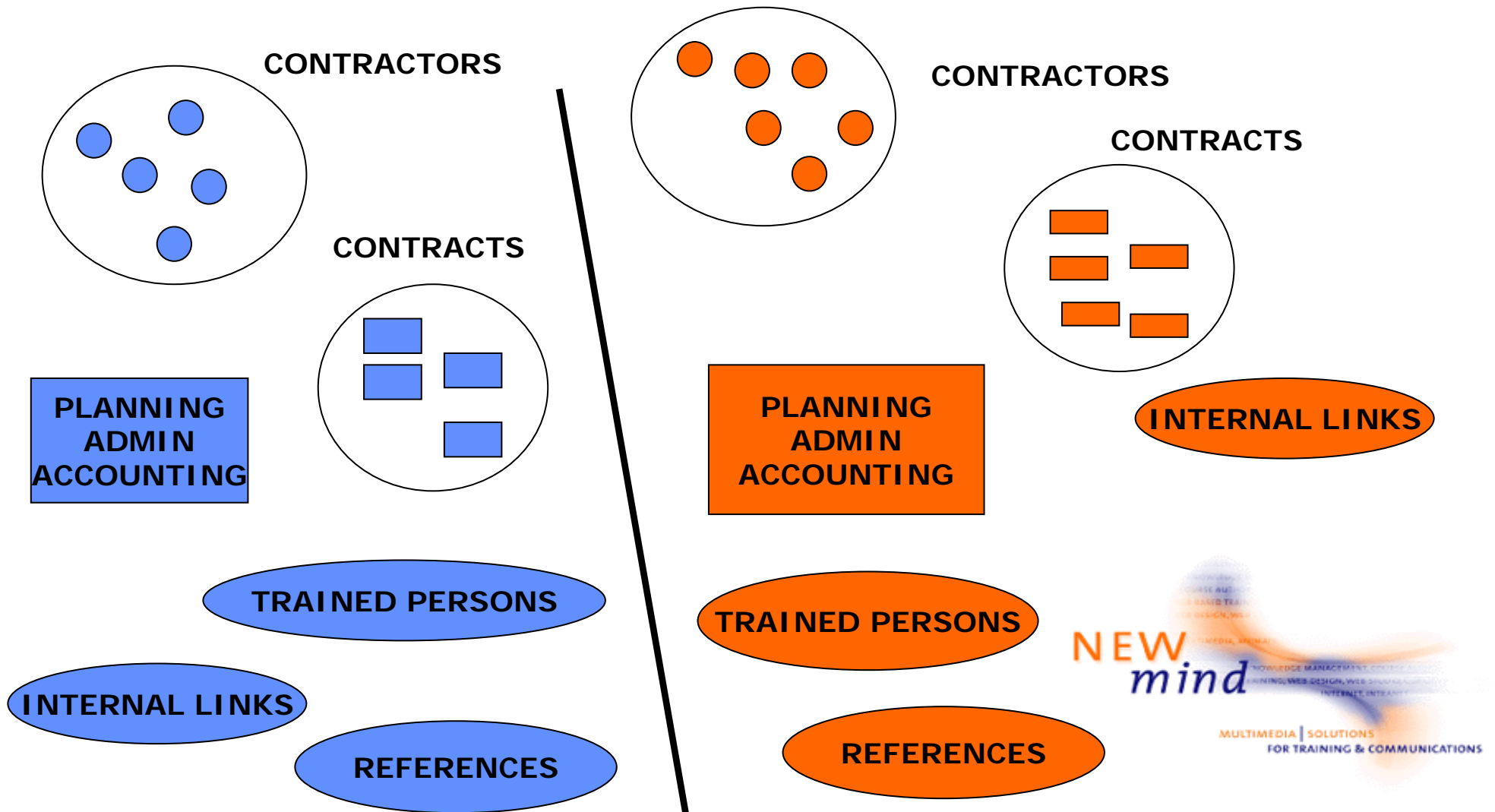



A merger: the challenges

Need to converge on common

- tools
- procedures
- vocabulary,...

Business processes loaded with "Know-how"

The conclusion :

- they limited the convergence on some tools
- all parties unhappy
- waste of Know-how





Car rental case

The statement

“Yes sir, drop your keys here, we will tell the administration”

The truth

Nothing happened

The conclusion

Business processes too narrow, don't capture new facts





Market research case

Telecom company

Visit to the brand new Market Research department

Observation

None of the industry data comes from available, public sources (professional organisations)

The conclusion

Business processes does not take knowledge sources into consideration





Expert system case

Electronics company

Huge investment : knowledge base of incidents and repair actions + expert system + training system

Results

Common sense basic statements for simple incidents

Too many possible tracks for sophisticated incidents (the search engine syndrom)

The conclusion

Lack of study of the repair process per se





Why KM ?

Our experience

- Technology based Learning
- Priorities, needs inventory
- Skills Management
- Human Resource policies
- Document and Content Management
- Knowledge Management

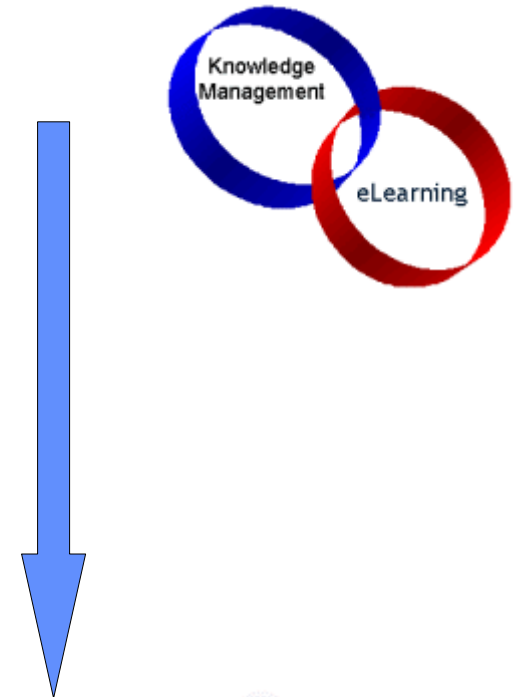



Observations

Technology based Learning solutions are often on the wrong track, very partial and limited in scope, because not anchored in the Knowledge picture of the company.

That is why we recommend the two domains to get closer.





Knowledge Management issues

- Often too abstract
- Lack of human involvement
- Driven by computer experts
- Out of focus
- Long process

WE NEED



- concrete
- tactical
- business focus
- involvement





Knowledge Mapping

Conceptual = a "taxonomy (*)," a method of hierarchically organising and classifying content.

()practice of classifying plants and animals according to their presumed natural relationships*

Competency = document the skills, positions, and career paths -
- to create a competency profile. cf 'yellow pages' directory,
which enables to find needed expertise

Social Network Mapping = shows networks of knowledge and
patterns of interaction

Procedural = mapping to a business process

*Source: French Caldwell (VP of
Information and Knowledge Management
at the Gartner Group)*





Tacit and Explicit

Explicit	Tacit
<p>You can write it down and teach. Easy to share. Pragmatic, formal, systematic, quantifiable. Increases immediate capabilities. Via words, textbooks, CBT,...</p>	<p>Tough to explain and to share. Idealistic, subjective. Shapes how we perceive the world around us. Intuitive, highly personal . Via figurative language and symbolism, metaphor, analogy. Cultural roots.</p>

source: Ikujiro Nonaka, The Knowledge-Creating Company, Harvard Business Review, November-December 1991





Definitions

Aristotle: episteme, praxis and **phronesis**

practical wisdom

Another:

- data when stored
- information when organised
- knowledge when **shared** and lever to **action**

Peter Drucker:

Knowledge is information that changes something or somebody -- either by becoming **grounds for actions**, or by making an individual (or an institution) capable of different or more effective action."





Convergence

Action
Sharing

Event



Knowledge



Action

→ Is sharing spontaneous?

Triggered by events

→ How does action take place?

Business process driven





Summary

From the previous observations, a solution is to look at the knowledge creation and use:

- triggered by events
- at the crossroads of business processes

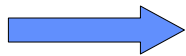

Business Process related Knowledge Mapping





Rummler-Brache

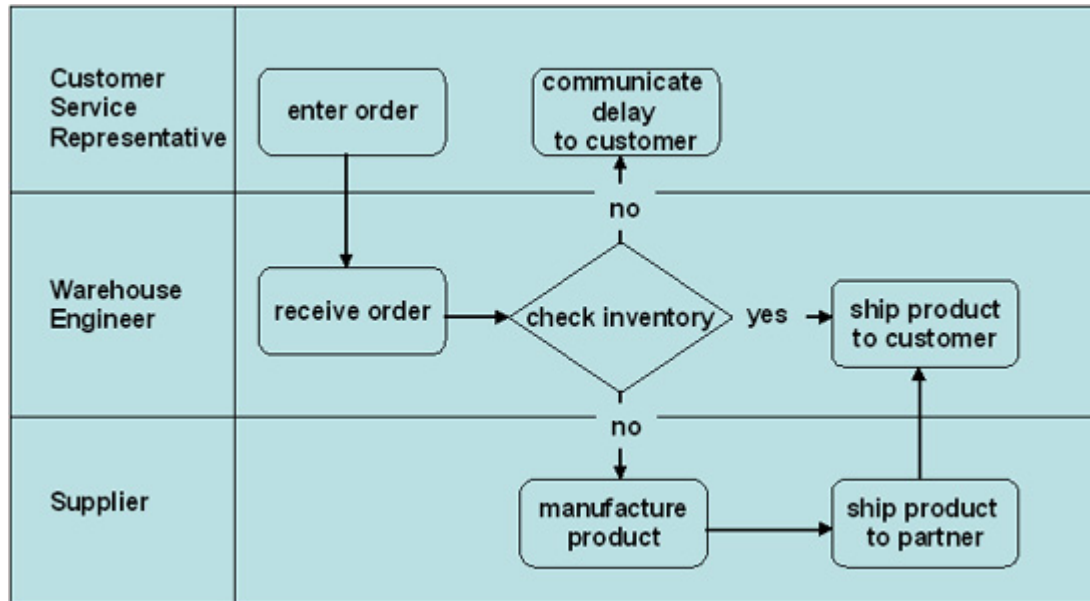

The "Swim lane" or Rummler-Brache approach is a technique for mapping organisational structure to processes. :organisational bands or lanes are placed on a page representing the process steps for a particular group or organisation.

from processdriven.org





IDEFO

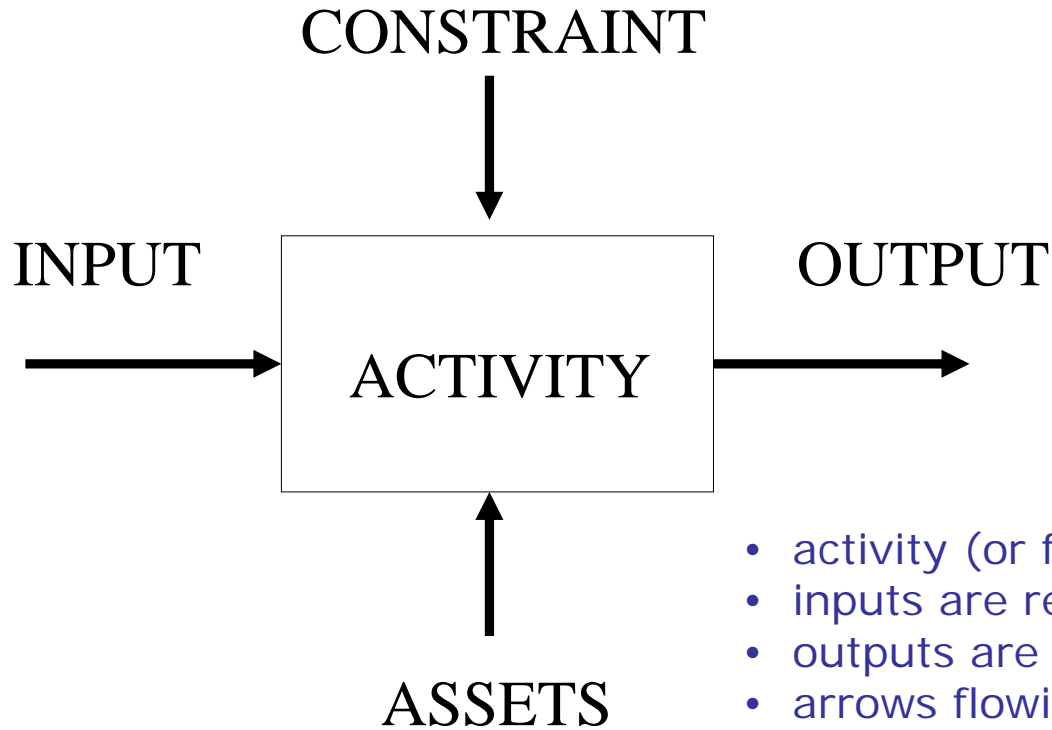

IDEFO is a method designed to model the decisions, actions, and activities of an organisation or system. It is a component of a family of modelling methods.

- activity (or function) is represented by the box
- inputs are represented by the left arrows
- outputs are represented by right arrows
- arrows flowing into the top portion of the box represent constraints or controls
- arrows flowing into the bottom of the activity box are the mechanisms or resources



Example

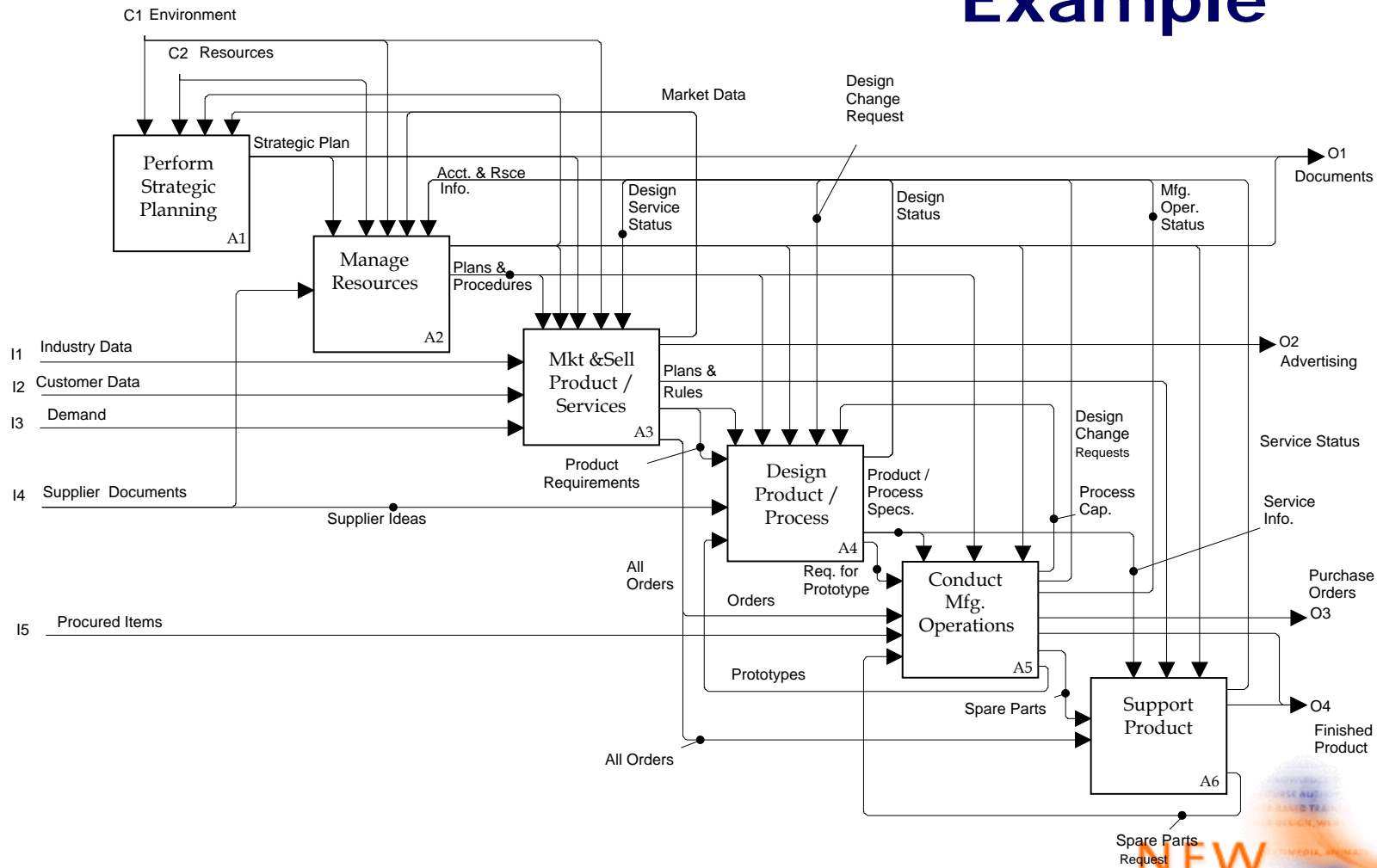

from Larry Whitman





How to do it?

- Teamwork
- Top down
- Cross functional
- Iterative
- Factual
- Add future needs and compare with current map
- Several supporting software applications

People don't argue with their own data. -- Bob Pike, Minneapolis





Add the Knowledge dimension

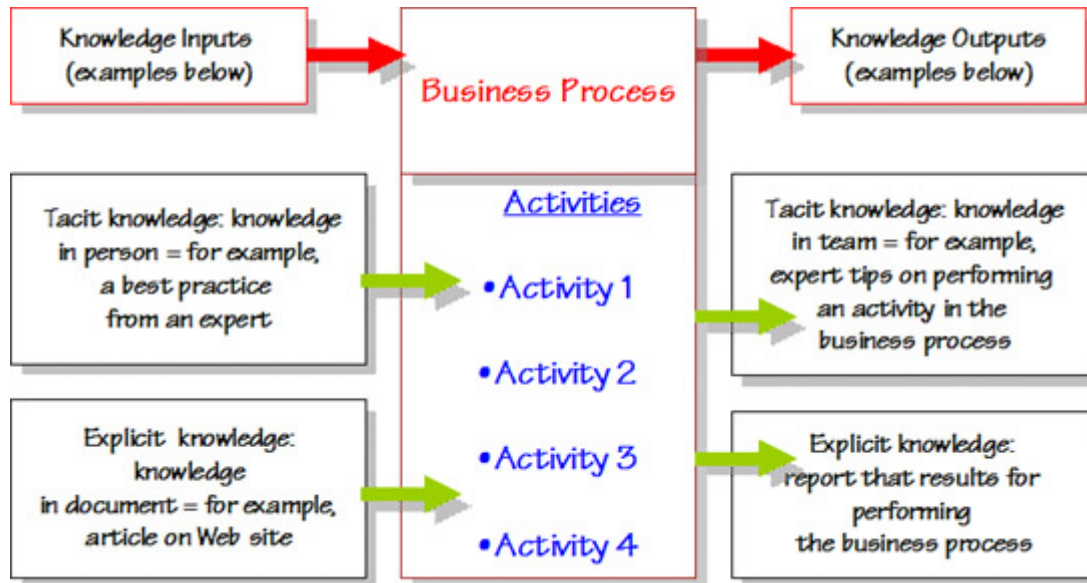

from Deborah Plumley





Steps

- Formal business process description
- Add the Knowledge dimension
- Analysis of the maps
 - what is critical, what adds value
 - what is missing?
 - what are the sources
 - who are the users
 - who is in charge?
- Deliverables
- Action plans





Form

Workshop

- preparation
- run (2-3 days) with key stakeholders
- document
- analyse and involve team
- conclude





Benefits

- Business processes are enriched
- The knowledge map is based on a structure, a backbone

By-products

- documentation creation
- incremental
- training needs in a business context
- team motivation





Conclusion

The ECLO network, with the broad skills base it represents, is ready to engage, in Europe, in Knowledge mapping projects. The technique presented, being so pragmatic and focusing on real activities and human involvement is without doubts, a positive step towards the Learning organisation.

